

**YASKAWA**

# GA700 AC DRIVES

FOR INDUSTRIAL APPLICATIONS



200V CLASS: 0.4 to 110kW  
400V CLASS: 0.4 to 630kW



# LIMITLESS POSSIBILITIES

Yaskawa's GA700 Series offers the best value proposition for industrial applications. The GA700 is the right choice with a compact, flexible, straightforward design by integrating and embedding key AC drive attributes focused on optimized installation and minimized start-up.



The GA700 strives to continue this tradition while advancing the product technology for current and future industry trends. These industry trends range from extending the product range, functional safety, network connectivity and flexible packaging to mobile-enabled functionality.

The GA700 is designed for ease of set-up and programming. The intuitive digital operator offers a soft key user interface and a programming environment with navigation wizards and customizable monitors for easy set-up. Programming and set-up of the motor is also made easier with the EZ Vector tuning-less control function. The GA700 package design is suitable for flexible environmental installations from the stand-alone to custom package requirements.





## OUR COMMITMENT TO YOU

Yaskawa's GA 700 Series offers the best value proposition for industrial applications by integrating and embedding key AC drive attributes.



200V CLASS: 0.4 to 110kW  
400V CLASS: 0.4 to 630kW

### EFFORTLESS NETWORK INTEGRATION

Supports all major networks with a new cost effective gateway feature

### ONE FOR ALL

Flexible motor control with one drive controlling any induction or permanent magnet motor

### POWERFUL CONFIGURATION TOOLS

Drive management with DriveWizard<sup>®</sup>  
Customizable with DriveWorksEZ<sup>®</sup>

### QUICK & EASY SET-UP

Reduce set-up time with an intuitive keypad, navigation and start-up wizards

### SAFE, CONVENIENT SET-UP AND MONITORING

Low voltage interface for safe programming access  
Maintain network communications even during loss of main input power

### INTEGRATED FUNCTIONAL SAFETY

Increased safety and reliability with STO SIL3 functional safety as standard

### MEETS GLOBAL STANDARDS

Local/global standards  
RoHS compliant

### ENVIRONMENTAL PROTECTION WITH FLEXIBLE PACKAGE DESIGN

Designed with flexibility to simplify installation and cabinet design



# Effortless network integration

GA700 drives support all major industrial communications to adapt to various factory automation networks. Reduce wiring when connecting to an upper level controller or PLC through available built-in protocols and/or dedicated communication options.

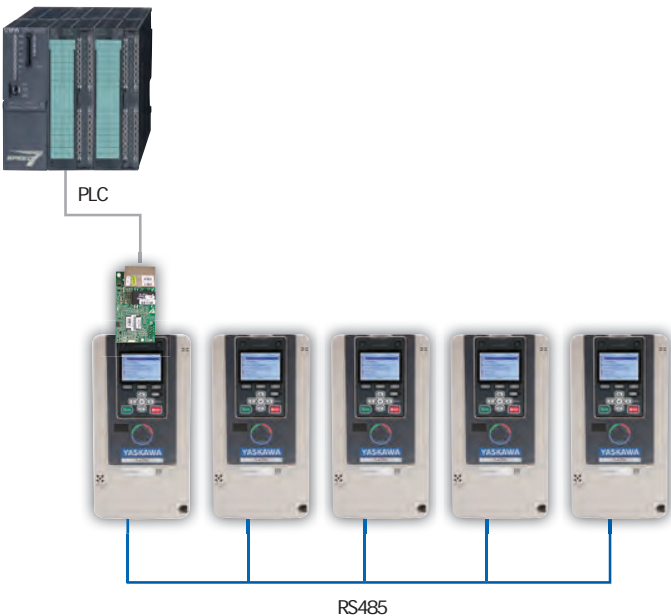

## INDUSTRIAL NETWORK COMMUNICATIONS

Network communications between drives can be simple and cost effective by utilizing a single communication option card while connecting the additional drives using the built-in RS485 Modbus protocol.

## EMBEDDED +24VDC INPUT ACCESS

Network communication can be maintained during loss of main input power utilizing the +24VDC input. An external +24VDC source can be connected directly to the GA700 without an additional +24VDC power supply option.

## Network integration benefits/features:

### SUPPORTS ALL MAJOR NETWORKS

- Network compliance tested
- Network up to 5 drives with a single communication card

### COST SAVINGS WITH BUILT-IN PROTOCOLS

- RS-422/485 MEMOBUS/Modbus protocol
- 115.2 kbps communication speeds

### MAINTAIN COMMUNICATION DURING MAIN POWER-LOSS

- Embedded +24VDC input control input power standard



DeviceNet™ EtherNet/IP™

EtherCAT®

ETHERNET POWERLINK

CC-Link

CANopen®

Modbus

MECHATROLINK

PROFINET®

PROFIBUS®



# One for all

Versatile motor control with one drive to control any induction or permanent magnet motor with or without an encoder device.



## Motor control benefits/features:

### FLEXIBLE MOTOR CONTROL

- Tuning-less with EZ vector
- Open/closed loop speed or torque control
- Induction/permanent magnet motors
- Synchronous reluctance (SynRM) motors
- 590Hz output frequency
- Zero speed control

### ENERGY SAVINGS

- High precision control
- Automatic energy efficiency optimizer with Smart Power Saver function

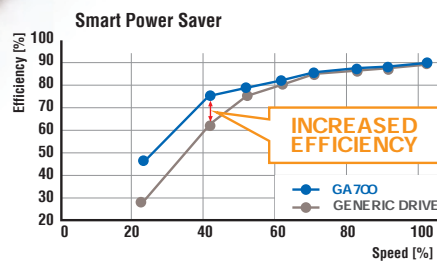
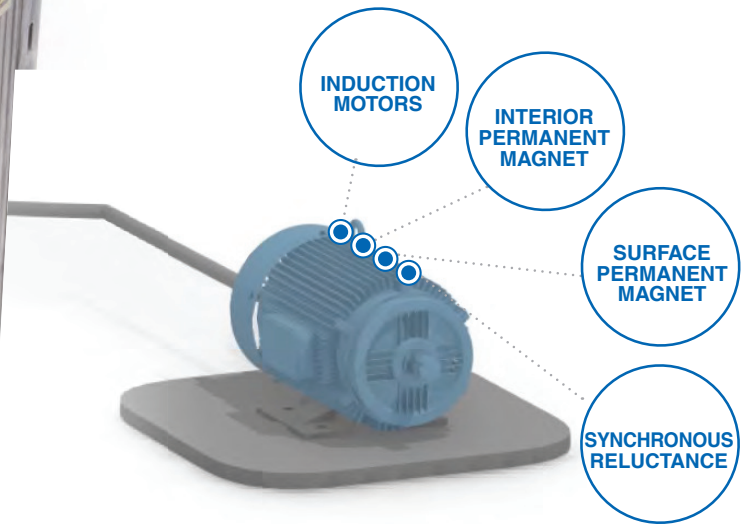

### SMART POWER SAVER

Energy savings can be further increased and automatically optimized with the Smart Power Saver function. The Smart Power Saver can minimize energy consumption through varying load and speed ranges achieving power optimization for energy cost reduction.

# Powerful configuration tools

DriveWizard<sup>®</sup> is an offline/online parameter and drive configuration tool. The easy and intuitive tool is used for setup, maintenance and troubleshooting offering parameter editing, storing and file comparison as well as online trending using the highly functional oscilloscope feature.

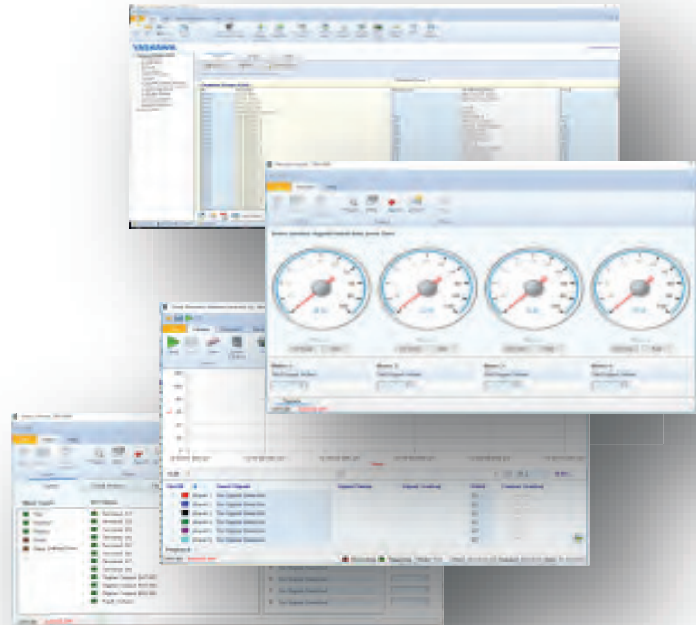

# Customizable

The GA700 further enhances the programming experience with DriveWorksEZ®. DriveWorksEZ® offers an icon-based, drag-n-drop graphical environment to add programmable functions that can tailor the drive to meet various machine and application requirements without the cost of external controllers, such as PLCs or additional controller hardware options.

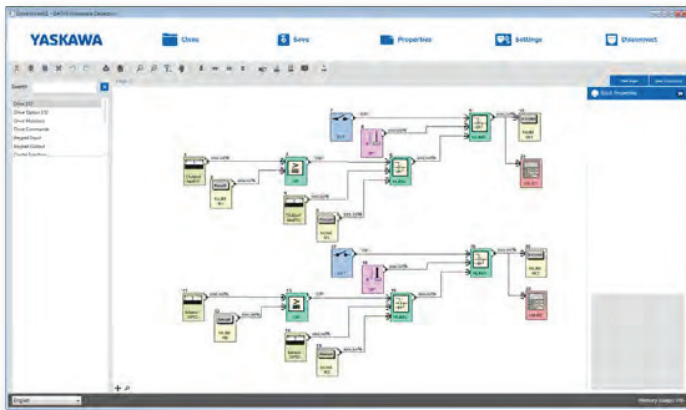

**CUSTOMIZED PROGRAMMING**  
DriveWorksEZ® is a drag-n-drop graphical interface using pre-tested function blocks. Create your own custom control with the aid of an online debugger program. Example application programs created by DriveWorksEZ include Winder, Laundry, etc.

## Application Toolbox benefits/ features:

### DRIVE MANAGEMENT WITH DRIVEWIZARD®

- Parameter management
- Online manual
- Report generation and export data
- 6 channels
- Real-time monitoring
- Access through USB, RS-232, EtherNet IP, Modbus TCP/IP, and PROFINET
- Automatic parameter conversion from previous series drives

### CUSTOMIZABLE WITH DRIVEWORKS EZ®

- Icon-based graphics
- Drag-n-drop graphical interface
- I/O, drive and network interface
- Select from 280+ function blocks
- Logic/math functions
- Timers/counters
- Subroutine creation
- Up to 200 connections

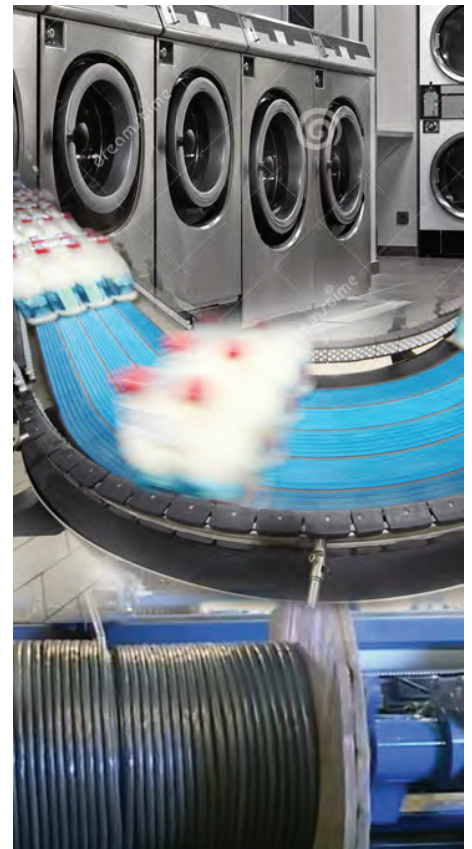



# Quick & easy set-up

The GA700 provides a user programming experience with an intuitively-designed keypad and tactile user interface. The programming set-up time is faster and easier when scrolling through the navigation menus and start-up wizards. The keypad programming is complimented by easy-to-understand iconic symbols.



## MOBILE DEVICE CONNECTIVITY

Drive programming, monitoring and troubleshooting is possible using your mobile device with DriveWizard mobile app. Mobile device connectivity is achieved through using the built-in USB port or wireless communication with the Bluetooth® LCD keypad option.



## Keypad benefits/features:

### REDUCE SET-UP TIME

- Start-up wizard
- Favorite parameter/monitor function
- Copy keypad
- Parameter set is backward compatible with previous generation drive products
- Fast navigation
- Help function

### DRIVE PARAMETER MANAGEMENT

- Copy keypad
- Storage of up to 4 drive parameter sets
- Datalogging with real-time stamped data and fault logging (up to 32GB micro SD)
- Data trending for energy consumption analysis
- Multiple parameter storage
- Automatic parameter back-up

### EASY TO USE

- LCD keypad with Bluetooth® option
- Display contrast control
- Real-time clock with time stamp
- Tactile feel buttons
- Remote mounting of keypad using standard RJ45 extension cable

### COPY FUNCTION

Drive parameters can be easily transferred (copied) to additional drives

### HI-RESOLUTION DISPLAY

The high resolution display offers clear and readable full text descriptions

### ADVANCED KEYPAD NAVIGATION

Faster scrolling and function keys offer faster navigation and short-cuts reducing programming time



### MICRO SD STORAGE

Micro SD for data logging storage

### REAL-TIME CLOCK

Real-time clock for time stamp of fault information (battery compartment in back)

### LCD KEYPAD WITH BLUETOOTH®

Wireless communication capability between the mobile device and drive

REAL-TIME CLOCK



MOTOR SETUP

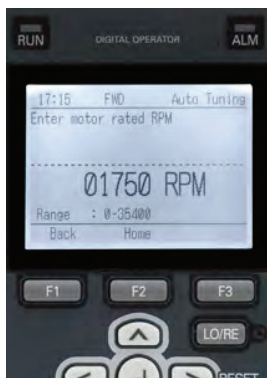

MONITOR

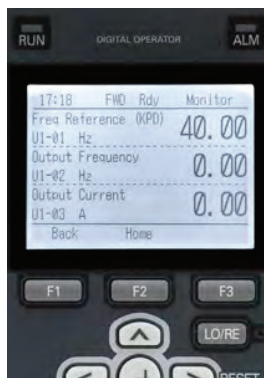

GRAPH MONITOR

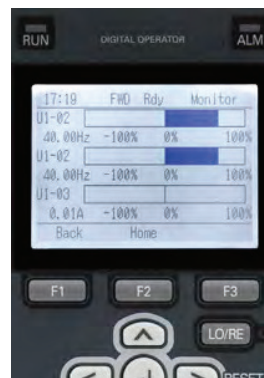

FAULT LOG

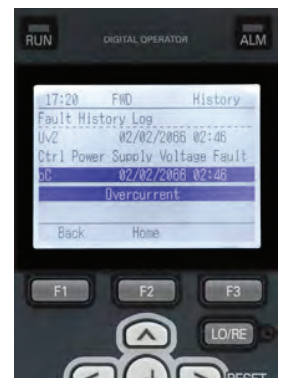

# Safe, convenient set-up and monitoring

The GA700 offers an additional attribute for programming access and control utilizing PC or mobile device. Whether interfacing with the GA700 using a PC interface or mobile device, drive programming, parameter access and monitoring can provide a safe and convenient method for drive set-up. The drive information and parameter storage can then be easily transferred and retrieved to and from the Yaskawa Drive cloud.







## Low power benefits/features:

### LOW VOLTAGE COMMISSIONING

- Embedded +24VDC control supply input
- Customer use +24VDC output
- Drive set-up without 3-phase power
- Firmware upgrades
- Datalogging/parameter storage
- Removable terminal board

### CLOUD SERVICE

- Online manual
- Parameter backup
- Troubleshooting tips
- Additional product data

### MOBILE APPS

- DriveWizard® mobile



### DRIVEWIZARD® MOBILE APPLICATION

By scanning the QR code can provide easy access to drive information and status using the DriveWizard mobile application software. Product information can be retrieved and stored using Yaskawa cloud service.

# Integrated functional safety

Installation reliability are increased with higher safety integrity levels available with the built-in STO feature. The GA700 is designed for SIL3 STO functional safety with 2-terminal-pin STO (Safe Torque Off) as standard.

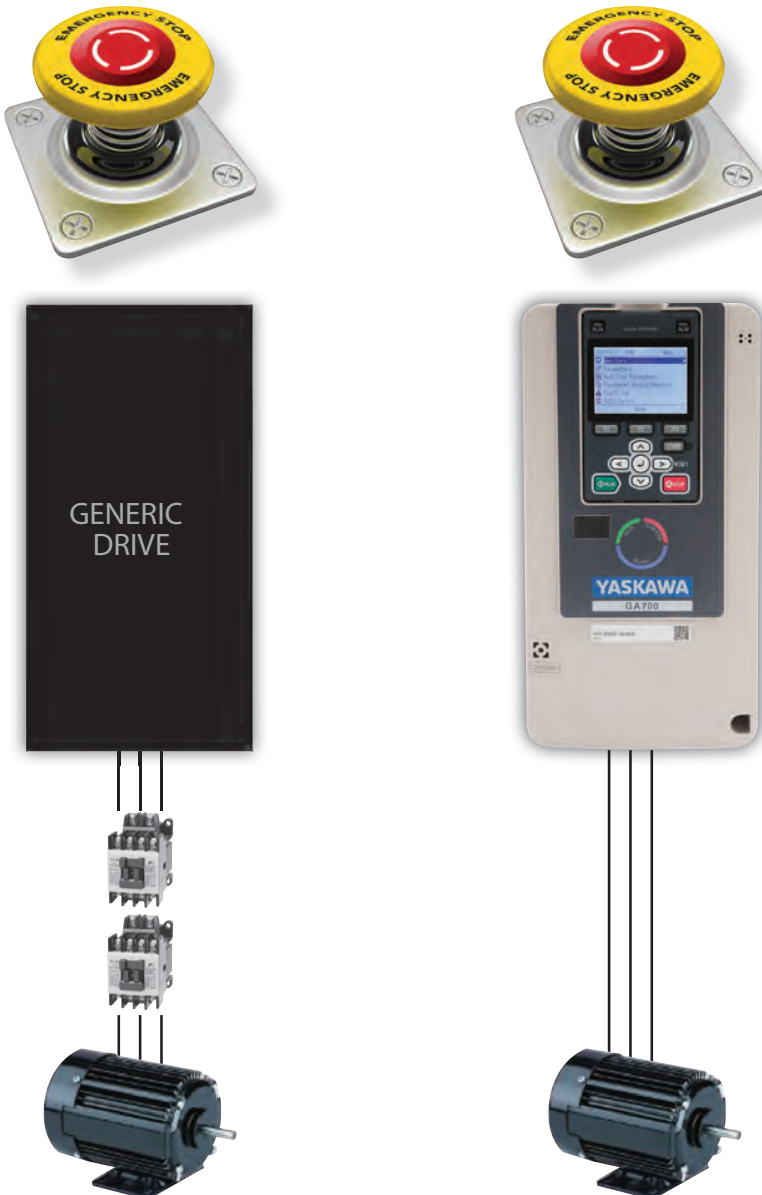

## Functional Safety benefits/ features:

### INCREASE RELIABILITY/SAFETY

- STO with SIL3/PLe according to IEC 61800-5-2/IEC 61508/ISO 13849
- EDM monitor
- Reduce parts count



**EMBEDDED FUNCTIONAL SAFETY**  
The built-in STO replaces mechanical emergency relays reducing parts. The electronic sequencing improves reliability and cost compared to mechanical components.

# Meets global standards

Globally certified to meet a wide range of application standards and compliance levels. Global standard such as UL, CE to application specific certifications.

## Standards benefits/features:

### LOCAL/GLOBAL STANDARDS

- UL/cUL/CSA
- CE
- TUV
- EAC
- RCM
- KC

### COMPLIANCE

- RoHS







# Environmental protection with flexible package design

Flexible product design that is adaptable for various environmental conditions. The enclosure is designed with flexibility for simple cabinet installation to outdoor exposure.



## COATED BOARD PROTECTION

Coated PCB's are available as standard complying with IEC 60721-3-3, class 3C2/3S2.

## Enhanced Product benefits/ features:

### INSTALLATION EASE – PANEL/ENCLOSURE

- IP20 standard
- NEMA 1 kit optional
- Type 12/IP55 protected heatsink
- IEC 60721-3-3, class 3C2/3S2 conformal coated boards
- Side-by-side mounting
- Built-in braking transistor (up to 75kW)

### REDUCE HARMONICS/ EMISSIONS

- Built-in C3/C2 filters as factory option
- Built-in DCL (above 18.5kW)



### PROTECTED HEATSINK FACTORY OPTION

The GA700 with a simplified flange design offers easy installation when mounting the heatsink outside the cabinet to reduce cabinet size. In addition, the factory optional Type 12/IP55 heatsink design can provide greater protection from dust particles while reducing cooling requirements resulting in smaller cabinets.



### 50% SMALLER THAN A1000

Next generation component selection and heat management design results in an approximate 50% reduction in physical size compare to previous generation products.

# SPECIFICATION OVERVIEW

OPERATING ENVIRONMENT		
Ambient Temperature	-10 to +50°C (IP00), -10 to +40°C (NEMA Type 1), up to +60°C with derating	
Storage Temperature	-40 to +70°C (short-term temperature during transportation)	
Humidity	95% RH or less (non-condensing)	
Altitude	Up to 1000 meters without derating, up to 4000m with output current and voltage derating.	
Shock	10 to 20Hz: 9.8 m/s <sup>2</sup> 20 to 55Hz: 5.9m/s <sup>2</sup> (2004 to 2211; 4002 to 4168) 2m/s <sup>2</sup> (2257 to 2415; 4208 to 4568), according to EN 60068-2-6	
Protection Design	IP20 Standard, NEMA 1 kit optional, IP55/Type 12 external heatsink (factory option), IP55/Type 12 standalone up to 90kW (400V class) (factory option)	
Mounting	Side-by-side up to 18.5/22kW, horizontal up to 55/75kW	
Conformal Coating (PCB's)	IEC 60721-3-3, Class 3CS (chemical gases), Class 3S2 (solid particles)	
Standards	CE, UL, cUL, CSA, KC, RCM, DNV-GL, ABS, NK, TUV, EAC, REACH, RoHS	
Functional Safety	IEC/EN 61508 SIL3 (STO)	
POWER RATINGS		
Overload Capacity	150%/1 min. (HD) or 110%/1min. (ND)	
Rated Voltage	200 to 240VAC, -15 to +10%	
	380 to 480VAC, -15 to 10%	
Capacity Range (HD)	200V Class: 0.4 to 110kW	
	400V Class: 0.4 to 315kWh	
Rated Frequency	50/60Hz +/-5%	
Output Voltage Accuracy	+/-5%	
Output Frequency	0 to 590Hz (*special software above 600Hz)	
Control Method	V/f, Open Loop (IM/PM), Advanced Open Loop (IM/PM), Closed Loop (IM/PM), EZ Open Loop Vector	
Motor Control	Induction Motor (IM), Permanent Magnetic Motor (IPM/SPM), Synchronous Reluctance Motor (SynRPM)	
OPTIONS		MODEL CODE
Communications	CANopen	SI-S3
	CC-Link	SI-C3
	DeviceNet	SI-N3
	EtherCAT	SI-ES3
	Ethernet/IP	SI-EN3
	Ethernet/IP dual port	SI-EN3/D
	MECHATROLINK-II	SI-T3
	MECHATROLINK-III	SI-ET3
	Modbus/TCP	SI-EM3
	Modbus/TCP dual port	SI-EM3/D
	POWERLINK	SI-EL3
	PROFIBUS-DP	SI-P3
	PROFINET	SI-EP3
	LONWORKS	SI-W3
	BACnet MSTP	SI-B3
APOGEE/METASYS	SI-J3	
Motor Feedback	Incremental Encoder (Line Drive)	PG-X3
	Complimentary Encoder (Open Collector)	PG-B3
	Absolute Encoder (EnDAT)	PG-F3
	SIN/COS Encoder	PG-E3
	Resolver Interface for TS2640N321E64	PG-RT3
Input/Output	Analog Input: 3-channel, Voltage +/-10V, 13-bit signed, Current (I) 4 to 20mA, 12-bit	AI-A3
	Analog Output: 2-channel, Voltage +/- 10V, 11-bit signed	AO-A3
	Digital Input: 16 Digital Inputs, +24V @ 8mA each, sink or source, multi-function or frequency reference (16 bit binary or BCD)	DI-A3
	Digital Output: 8-channel, 6 photocoupler (48V, 50mA or less), 2 relay contacts (250VAC/30VDC, 1 A max.)	DO-A3



# CONNECTION DIAGRAM

## Standard Connection Diagram Multi-Function Photocoupler Output Type (Standard)

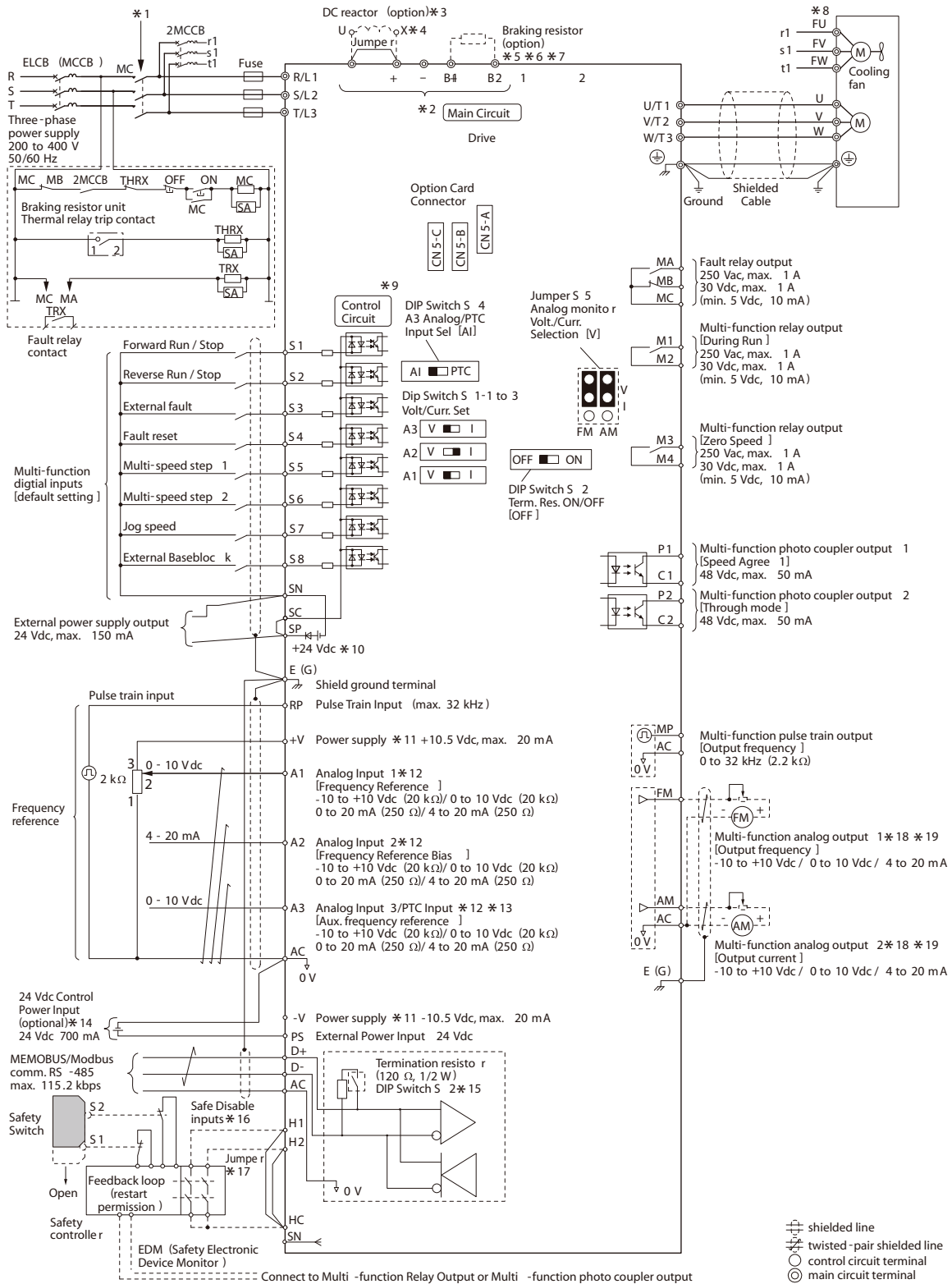

# RATINGS & SPECIFICATIONS

## Catalog Number Designation

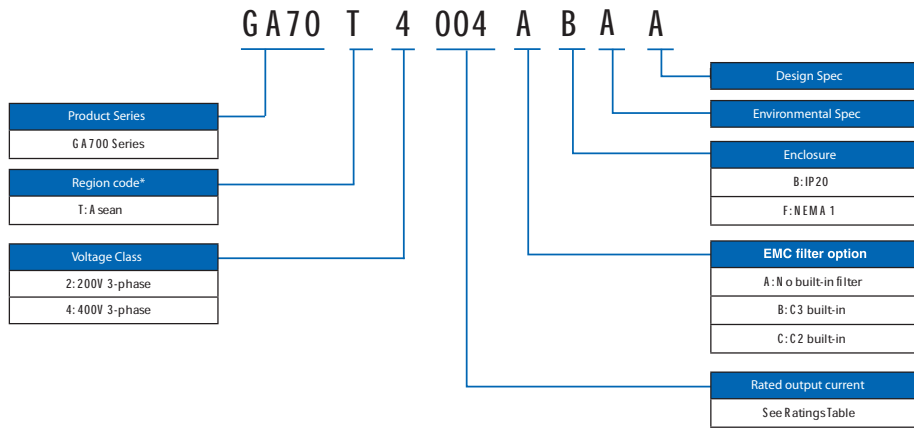

## 200V Class

Catalog# GA70T	Max applicable motor		Output		Dimensions (mm)		
	HD [kW]	ND [kW]	Rated Output Current [Amps] HD	Rated Output Current [Amps] ND	H	W	D
2004	0.4	v7.5	3.2	3.5	260	140	176
2006	0.75	1.1	5	6			
2008	1.1	1.5	6.9	8			
2010	1.5	2.2	8	9.6			
2012	2.2	3	11	12.2			
2018	3	3.7	14	17.5			
2021	3.7	5.5	17.5	21	350	220	227
2030	5.5	7.5	25	30			
2042	7.5	11	33	42	400	240	280
2056	11	15	47	56			
2070	15	18.5	60	70	450	255	280
2082	18.5	22	75	82			
2110	22	30	88	110	543	264	335
2138	30	37	115	138			
2169	37	45	145	169	700	312	420
2211	45	55	180	211			
2257	55	75	215	257	801	440	473
2313	75	90	283	313			
2360	90	110	346	360			
2415	110	-	415	-			

# RATINGS & SPECIFICATIONS

## 400V Class

Catalog# GA70T	Max applicable motor		Output		Dimensions (mm)		
	380 to 460VAC		460VAC		H	W	D
	HD [kW]	ND [kW]	Rated Output Current [Amps] HD	Rated Output Current [Amps] ND			
4002	0.4	0.75	1.8	2.1	260	140	176
4004	0.75	1.5	3.4	4.1			
4005	1.5	2.2	4.8	5.4			
4007	2.2	3.0	5.5	7.1			
4009	3.0	3.7	7.2	8.9			
4012	3.7	5.5	9.2	11.9			
4018	5.5	7.5	14.8	17.5			
4023	7.5	11	18	23.4			211
4031	11	15	24	31			
4038	15	18.5	31	38	300	180	202
4044	18.5	22	39	44	350	220	227
4060	22	30	45	59.6			246
4075	30	37	60	74.9	400	240	280
4089	37	45	75	89.2	450	255	280
4103	45	55	91	103			
4140	55	75	112	140	543	264	335
4168	75	90	150	168			
4208	90	110	180	208			
4250	110	132	216	250	700	312	420
4296	132	160	260	296			
4371	160	200	304	371	801	440	473
4389	200	220	371	389			
4453	220	250	414	453			
4568	250	315	453	568	1141	511	481
4675	315	355	605	675			
4930	450	500	810	930	1380	1001	440
412H	560	630	1090	1200			





# Global Service Network



Region	Service Area	Service Location	Service Agency	Telephone/Fax
North America	U.S.A.	Chicago (HQ) Los Angeles San Francisco New Jersey Boston Ohio North Carolina	① YASKAWA AMERICA INC.	Headquarters ☎ +1-847-887-7000 FAX +1-847-887-7310
	Mexico	Mexico City	② PILLAR MEXICANA. S.A. DE C.V.	☎ +52-555-660-5553 FAX +52-555-651-5573
South America	South America	São Paulo	③ YASKAWA ELÉTRICO DO BRASIL LTDA.	☎ +55-11-3585-1100 FAX +55-11-5581-8795
	Colombia	Bogota	④ VARIADORES LTD.A.	☎ +57-1-428-4225 FAX +57-1-428-2173
Europe	Europe, South Africa	Frankfurt	⑤ YASKAWA EUROPE GmbH	☎ +49-6196-569-300 FAX +49-6196-569-398
Asia	Japan	Tokyo, offices nationwide	⑥ YASKAWA ELECTRIC CORPORATION (Manufacturing, sales)	☎ +81-3-5402-4502 FAX +81-3-5402-4580
			⑦ YASKAWA ELECTRIC ENGINEERING CORPORATION (After-sales service)	☎ +81-4-2931-1810 FAX +81-4-2931-1811
	South Korea	Seoul	⑧ YASKAWA ELECTRIC KOREA CORPORATION (Sales)	☎ +82-2-784-7844 FAX +82-2-784-8495
			⑨ YASKAWA ENGINEERING KOREA CORPORATION (After-sales service)	☎ +82-2-3775-0337 FAX +82-2-3775-0338
	China	Beijing, Guangzhou, Shanghai	⑩ YASKAWA ELECTRIC (CHINA) CO., LTD.	☎ +86-21-5385-2200 FAX +86-21-5385-3299
	Taiwan	Taipei	⑪ YASKAWA ELECTRIC TAIWAN CORPORATION	☎ +886-2-2502-5003 FAX +886-2-2505-1280
	Singapore	Singapore	⑫ YASKAWA ELECTRIC (SINGAPORE) PTE LTD	☎ +65-6282-3003 FAX +65-6289-3003
	Thailand	Bangkok	⑬ YASKAWA ELECTRIC (THAILAND) CO., LTD.	☎ +66-2-017-0099 FAX +66-2-017-0090
	India	Bangalore	⑭ YASKAWA INDIA PRIVATE LIMITED	☎ +91-80-4244-1900 FAX +91-80-4244-1901
	Indonesia	Jakarta	⑮ PT. YASKAWA ELECTRIC INDONESIA	☎ +62-21-2982-6470 FAX +62-21-2982-6471
			⑯ YASKAWA ELECTRIC VIETNAM CO., LTD	☎ +84-8-3822-8680 FAX +84-8-3822-8780
Vietnam	Ho Chi Minh	⑯ YASKAWA ELECTRIC VIETNAM CO., LTD	☎ +84-4-3634-3953 FAX +84-4-3654-3954	
	Hanoi			
Oceania	Australia	Contact to service agency in Singapore ( ⑫ ).		

# GA700

## Yaskawa Singapore Group

### YASKAWA ELECTRIC (SINGAPORE) PTE LTD

Address: 151 Lorong Chuan, #04-02A New Tech Park Singapore 556741

Tel: +65 6282 3003 Fax: +65 6289 3003

Email: [info.ysp@yaskawa.com.sg](mailto:info.ysp@yaskawa.com.sg)

Website: <http://www.yaskawa.com.sg/>

### YASKAWA ELECTRIC (THAILAND) CO., LTD.

Address: 1st - 5th Floor, Flourish Building, Soi Rachadapisek 18, Rachadapisek Road, Huaykwang Bangkok 10310, Thailand.

Tel: +66 2 017 0099 Fax: +66 2 017 0090

Website: <http://www.yaskawa.co.th/>

### PT.YASKAWA ELECTRIC INDONESIA

Address: Secure Building – Gedung B, GF & 1st F1

Jl. Raya Protokol Halim Perdana Kusuma

Jakarta 13610, Indonesia

Tel: +62 21 2982 6470 Fax: +62 21 2982 6471

Website: <http://www.yaskawa.co.id>

### YASKAWA ELECTRIC VIETNAM CO., LTD

#### Ho Chi Minh Office

Address: Suite 1904A, 19th Floor, Ccntcc Tower,  
72-74 Nguyen Thi Minh Khai, Ward 6, District 3,  
Ho Chi Minh City

Tel: +84 8 3822 8680 Fax: +84 8 3822 8780

#### Hanoi Office

Address: 2nd Floor, Somerset Hoa Binh Hanoi

Tel: +84 4 3634 3953 Fax: +84 4 3654 3954

---

**YASKAWA**

Yaskawa Electric (Singapore) Pte Ltd

In the event that the end user of this product is to be the military and said product is to be employed in any weapons systems or the manufacture thereof, the export will fall under the relevant regulations as stipulated in the Foreign Exchange and Foreign Trade Regulations. Therefore, be sure to follow all procedures and submit all relevant documentation according to any and all rules, regulations and laws that may apply. Specification, rated values and dimensions are subject to change without notice for ongoing product modifications and improvements.

Document No.: YSP KAEP-C710617 00B <1> =0  
Published in August 2016